

Selection Guide of SiC Schottky Diode in CCM PFC Applications

Silicon Carbide Schottky diodes are ideal devices for CCM PFC boost diode applications because of the superior reverse recovery characteristics – zero reverse recovery current. Selection of a SiC Schottky boost diode is different from its counter part-- Silicon ultra fast soft recovery diode, which is normally oversized due to the excessive reverse recovery energy loss. A Mathcad file has been created in order to provide power supply designers a detailed explanation and calculation on how to select appropriate SiC Schottkys for different power rated CCM PFC boost converters.

Introduction

Active power factor correction has been widely adopted in AC/DC Switch Mode Power Supply (SMPS) designs due to the mandatory IEC-61000-4-3 requirements since January 2001. For SMPS with output power rating higher than 300W, the active PFC boost converters are normally designed to operate in Continuous Conduction Mode (CCM). The SiC Schottkys are ideal for this application. Additionally, many lower power SMPS designs are adopting PFC in order to meet new efficiency standards.

A typical active PFC boost converter is shown in Figure 1.

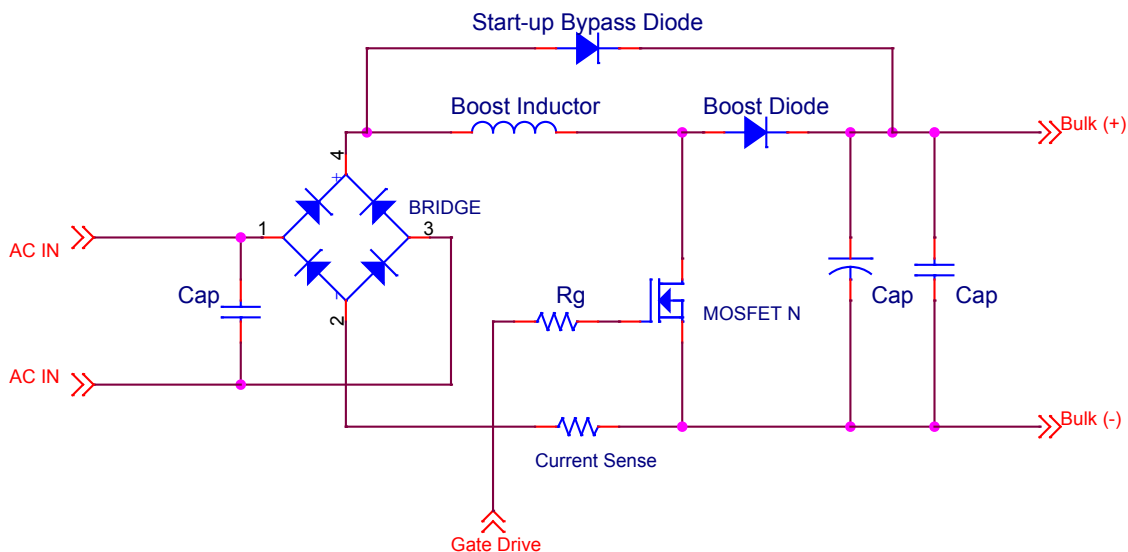

Figure 1. Active Power Factor Correction Boost Converter

During the boost diode turn-off and boost MOSFET turn-on transition, the excessive reverse recovery current in a Silicon diode not only contributes to the switching loss in the diode itself but also to the MOSFET turn-on switching loss, which leads to the requirement of larger die devices for both MOSFET and boost diode in order to meet efficiency and thermal specifications.

A Silicon Carbide Schottky diode is ideal for this application because of its virtual zero reverse recovery current. The switching loss in the diode will be reduced drastically, as well as the turn-on switching loss in the boost MOSFET. This will result in both boost MOSFET and diode die size reduction. Also, the snubber circuit for the Silicon boost diode and MOSFET can usually be eliminated from the circuit. Use of SiC Schottky diodes will provide a better overall system solution in terms of higher efficiency, less EMI noise, smaller heat sink volume and PCB area. In addition, lower component count that not only reduces component cost, but will also reduce material handling time, board assembly and in circuit testing time to save manufacturing cost.

SiC Schottky Diodes

Silicon Carbide is a wide bandgap, high breakdown field material allowing high voltage Schottky diodes to be made. SiC Schottky diodes with 300, 600 and 1200-volt are commercially available at CREE. The 600-volt diodes are available with 1, 2, 4, 6, 10 and 20-amp current ratings. The 1200-volt diodes are available with 5, 10 and 20-amp current ratings. The main advantage of a high voltage SiC Schottky diode lies in its superior dynamic performance. Schottky diodes are majority carrier devices and thus do not store charge in their junctions. The reverse recovery charge in the SiC Schottky diode is extremely low and is only the result of junction capacitance, not stored charge. Furthermore, unlike the silicon PiN diode, the reverse recovery characteristics of SiC Schottkys are independent of di/dt, forward current and junction temperature. The maximum junction temperature of 175°C in the SiC Schottkys represents the actual operational temperature. The ultra-low junction charge in SiC Schottkys results in reduced switching losses in a typical hard switched CCM PFC boost converter application.

The typical forward characteristics of a 10-amp SiC Schottky diode is as shown in Figure 2.

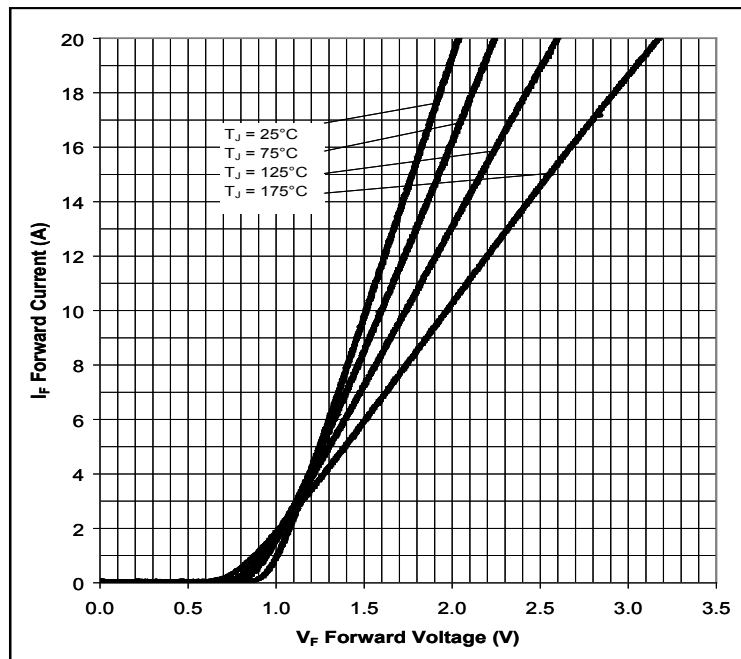

Figure 2. 10A/600V SiC Schottky Diode (CSD10060) Forward Characteristics

The SiC Schottky diode forward characteristics can be modeled as a temperature dependant forward voltage source V_d and resistor R_d . Notice that the SiC Schottkys have positive temperature coefficient that makes parallel operation of these devices an easy task. V_d and R_d values at the given junction temperature can be calculated from the following equations.

$$V_d = \alpha \cdot T_j + V_{d0}$$

$$R_d = \beta \cdot T_j + R_{d0}$$

Where a , b , V_{d0} , and R_{d0} are extrapolated from the empirical forward characteristic measurement data.

The forward voltage drop of a SiC Schottky diode at any given forward bias current and given junction temperature can be easily calculated from following equation, where V_d and R_d are calculated from previous equations.

$$V_F = I_F \cdot R_d + V_d$$

Power Loss Calculation of SiC Boost Diode in CCM PFC Applications

The calculation of power loss in the boost diode is important for two reasons. First, the current handling capability of the diode is simply a function of the power loss and the operating junction temperature. Thus by calculating the power loss, designers can be assured of choosing an adequately sized diode. Second, the Mathcad program allows designers to choose a diode based upon their efficiency goals.

The power loss in the boost diode consists of conduction loss and switching loss. The conduction loss is mainly caused by diode forward voltage drop at given forward bias current. The switching loss is from the reverse recovery energy loss. In SiC Schottky diodes, the conduction loss is the main power loss, and the switching loss is almost negligible since the reverse recovery current is near to zero. However in silicon boost diode the reverse recovery energy loss is much higher compared to conduction loss so that power supply designers have to choose much larger devices (both boost diode and MOSFET) in order to meet efficiency and thermal requirements. To avoid common misconception on replacing silicon diode with same current rating SiC devices, a step-by-step SiC Schottky boost diode power loss Mathcad file has been created so as to give SMPS designers an insight on why and how a much smaller current rating SiC Schottky diode can replace a much larger silicon boost diode.

The Mathcad file allows power supply designers to calculate the SiC Schottky boost diode power loss with any given design specifications.

The calculation is based on the operation of CCM PFC boost converter. Assuming unity power factor, the line current is in phase and shape with the input line voltage – a sinusoidal waveform, and the PFC output voltage is DC.

The boost diode conduction loss is calculated from using the SiC schottky diode equivalent circuit model of V_d in series with R_d . The switching loss is calculated from the energy loss caused by junction capacitance charge at given operating voltage over one switching cycle and multiplying by the switching frequency. Note that the loss caused by this capacitive charge is included in this loss model, however the loss is usually seen in the boost MOSFET. The detailed calculation and derivation are given in the Mathcad file: www.cree.com/products/power_docs.asp

The conduction loss of a SiC Schottky diode in a CCM PFC boost converter is as follows.

$$P_{d_cond} = I_{d_rms}^2 \cdot R_d + I_o \cdot V_d$$

Where I_o is the output current of the PFC converter, V_d and R_d are the equivalent resistance and forward voltage drop at given junction temperature of the SiC Schottky diode, h is the expected efficiency of the PFC converter, and I_{d_rms} is the RMS current of the boost diode over one line cycle at given input voltage, PFC output voltage and load current.

$$I_{d_rms} = \frac{I_o}{\eta} \cdot \sqrt{\frac{16 \cdot V_o}{3 \cdot \pi \cdot V_{in}}}$$

The switching loss of a SiC Schottky diode in a CCM PFC boost converter can be calculated from following equation.

$$P_{d_sw} = Q_c \cdot V_o \cdot f_s$$

Where Q_c is the total Schottky diode junction charge at specified voltage, V_o is the PFC output voltage, and f_s is the PFC converter switching frequency.

The over all diode loss in a CCM PFC boost converter is the summation of the conduction loss and switching loss.

$$P_d = P_{d_cond} + P_{d_sw}$$

The junction temperature rise can be calculated based on the junction to case thermal resistance given in the datasheets. The power supply designers can decide which Schottky diode should be used in a specific PFC application so that the device is operating with certain thermal margin and also meeting the efficiency specification.

Summary

Choosing a SiC Schottky boost diode is different from a Silicon diode due to the virtual zero reverse recovery current of the SiC Schottkys. The calculation is simplified since the SiC Schottky reverse recovery characteristics are independent from di/dt, forward bias current, and junction temperature. In general, an oversized Silicon diode has to be chosen in PFC application in order to meet thermal and efficiency requirements due to the excessive reverse recovery energy loss. In SiC Schottky case, the diode current rating or die size can be reduced drastically in comparison to Silicon diode in a same power rated PFC application. A Mathcad file has been created for the detailed equation derivation and power loss calculation for power supply designers to choose appropriately rated SiC Schottky diodes for the CCM PFC applications.